

- > above-ground installation.
- > typically installed in a Screen Print workshop.
- > this tank design contains and slows the flow of waste to allow any solvents and/or oil to float and separate from the cleaner water which flows out to sewer. Collected waste should be drained from the tank periodically and disposed as directed by local authorities.

Above-ground

Capacity litres	External Tank Dimensions mm			
	Length	Width	Water	Height
100	750	450	300	500
250	900	530	530	730
600	1500	600	680	1080
1100	1900	600	1000	1400
2000	2200	900	1000	1400

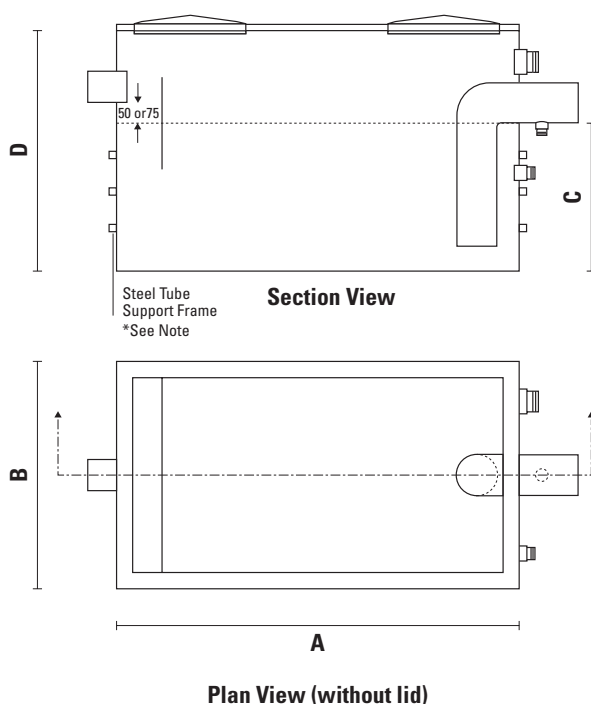

Solvent and Oil Interceptor model VP8

- > Manufactured from 6mm Polypropylene (PP), this tank is suitable for above-ground installation.
- > The tank is supplied with:
 - a removable airtight cover
 - 25mm sampling valve socket (valve not included)
 - 25mm drain valve socket (valve not included)
 - threaded vent socket
- > Tank dimensions and pipework positions conform to Trade Waste recommendations but may be arranged during manufacture to suit the installation requirement.
- > When space limitations dictate, equivalent capacity tanks can be manufactured to order
- > *Note: Tanks larger than 250 litres capacity are fitted with an external steel support frame. Allow 50mm all round
- > External tank height dimension (D) does not include the height of the lids (65mm)

- > below-ground installation.
- > typically installed in a Screen Print workshop.
- > this tank design contains and slows the flow of waste to allow any solvents and/or oil to float and separate from the cleaner water which flows out to sewer. Collected waste should be drained from the tank periodically and disposed as directed by local authorities.

Below-ground

Capacity litres	Internal Dimensions mm			
	Length	Width	Water	Height
600	1400	750	570	970
1140	1900	600	1000	1400
2000	2400	750	1120	1520

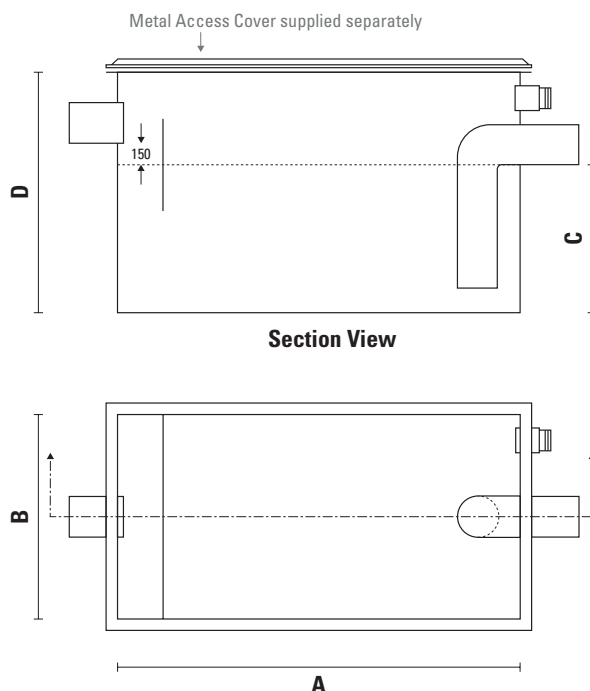

Solvent and Oil Interceptor model VP8

- > Manufactured from 6mm Polypropylene (PP) or Polyethylene (PE), this tank is suitable for low-ground installations.
- > The tank must be surrounded with 100mm thick concrete walls and base.
- > Note: The tank must be adequately supported internally to prevent the walls from collapsing when concrete is being poured.
- > Inlet, Outlet and Vent pipe nozzles are 100mm nb.
- > Tank dimensions and pipework positions conform to Trade Waste recommendations but may be arranged during manufacture to suit the installation requirement.
- > When space limitations dictate, equivalent capacity tanks can be manufactured to order.
- > Access covers (supplied separately) capable of being removed by one man should be fitted on top.
- > Access covers are available in various types including concrete in-fill, solid top and tiling edge. Weight loading must also be specified as required (i.e. pedestrian, car or heavy truck).
- > Below-ground tank is fitted with a 50mm flat-rim flange and external keying strips.

INSTALLATION & CLEANING GUIDELINES

ABOVE GROUND TANKS

The information provided herein is informative only and it applies to the above-ground installation of plastic fabricated Trade Waste Pre-Treatment Tanks. As rules and regulations differ from region to region, prior to proceeding we recommend the installing person verify that the procedures mentioned in this document satisfy the requirements of the local Authorities.

Trade Waste Authorities state that above-ground tanks must be installed on a level concrete pad.

Any portion of a tank installed below ground should be surrounded with a minimum of 100mm thick concrete – walls and base.

Siting Considerations

1. The tank should be located as close as practical to the source of contaminated water.
2. Ensure ease of accessibility for maintenance.
3. A water tap for the purpose of wash-down should be located nearby and must be fitted with backflow prevention device.
4. Grease Traps should not be installed in direct sunlight.

Site Preparation

5. Verify that inlet, outlet and vent pipe levels match the level of the pipe spigots on the tank.
6. If not already in place pour or install a level concrete pad for the tank to sit on. The concrete should be a minimum of 28mpa. Tanks in excess of 2000lt should have a pad at least 100mm thick.
7. The concrete slab or pad must support the entire length and width of the tank.
8. Do not remove the steel support frame (if fitted) from the tank.
9. If the tank is installed in an area exposed to vehicle traffic, bollards should be positioned to protect the tank.

Connections

10. Connections to be in accordance with Trade Waste and Plumbing Industry Commission guidelines and to comply with AS/NZ3500.2.
11. The Trade Waste department of the local water authority must approve all grease trap and trade waste interceptor installations prior to work commencing. Interceptors installed without approval may not be accepted for use.

Grease Trap Cleaning

12. Clean outs to be performed in accordance with the trade waste agreement with your local water authority.
13. The contractor is to un-screw the screw-in access cover (if fitted).
14. Contents to be pumped out via the suction hose attached to the pump truck.
15. With the suction hose still inside the tank chamber the entire internal surface is to be hosed down to remove residual grease build up.
16. Tank walls may be scrapped down to remove any solid accumulation.
17. Lid seals should be wiped clean, the seal checked for integrity and the screw-in access covers replaced or clamp down lids reinstalled.

Typical Above Ground Tank installation

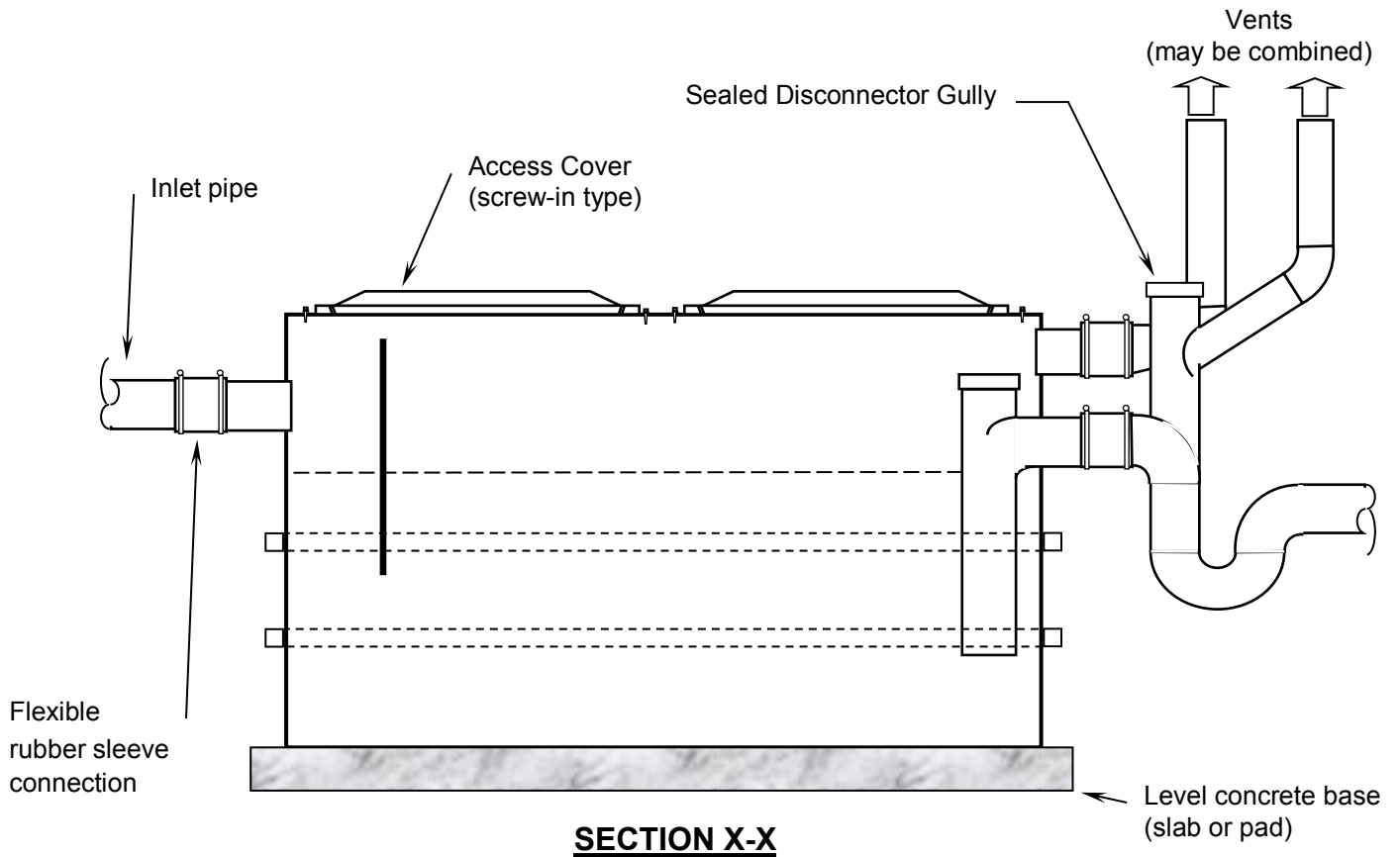

NOTE: Baffle and internal pipe configurations vary according to tank type capacity and/or customer requirements. All attempts should be made to ensure external connections correspond as close as possible to these drawings.

Installation and approval conditions may vary from region to region. This information is provided as a guide only for a typical above-ground tank installation. The pipe connection diagram is for indicative purposes only. Viking Plastics reserves the right to alter or change information at any time and without notice.

INSTALLATION GUIDELINES

BELOW GROUND TANKS - PANELTIM™

The information provided herein is informative only and it applies to the below-ground installation of **Paneltim™** fabricated Trade Waste Pre-Treatment Tanks. As rules and regulations differ from region to region, prior to proceeding we recommend the installer verify that the procedures mentioned in this document satisfy the requirements of the local Authorities and you follow appropriate and approved excavation practices. In most cases a geo-technical report will determine back-fill requirements.

'Paneltim™' tanks do not need to be surrounded with concrete (apart from 150x150 plinth).

Installations subject to Heavy traffic loads or commercial vehicles must be surrounded with reinforced concrete pavement at least 2mt in each direction (depth to be determined by others).

Siting Considerations

1. The tank should be located as close as practical to source of contaminated water.
2. Ease of accessibility for maintenance.
3. Water tap for the purpose of wash-down should be located nearby and be fitted with backflow prevention device.
4. The load-rating of the tank cover must be adequate for the expected traffic conditions.
5. For some excavations you may require a geotechnical report for ground stability and off-sets from buildings. These recommendations will determine back-fill requirements. Also determine the location of underground services before you dig.

Excavation & Preparation

6. The ideal excavation size will be at least 150mm clear of the tank base and all four sides.
7. Allow for thickness of cover height when excavating.
8. In the event that the sub-surface earth is particularly wet or soft, the earth under the tank should be compacted and, if necessary, filled with a layer of 20mm crushed rock at least 150mm deep. (additional to 150mm back-fill material)
9. Verify that inlet, outlet and vent pipe levels match the level of the pipe spigots on the tank.

Placing Tank

10. Fill bottom of excavation with a minimum of 150mm crushed rock (6mm aggregate)
11. Place tank on top of crushed rock base.
12. Ensure tank is plumb and pipe tails are connected with rubber sleaved joiners.
13. Backfill with 6mm aggregate evenly around the tank to prevent lateral movement.
14. Backfill in layers approx. 150mm deep and lightly compact (by foot is acceptable).
15. Backfill to 150mm from top of tank. (top 150mm and tank lid is to be concreted in place).
16. Lightly compact crushed rock – do not over compact. Over-compacting may cause tank walls to bulge inward.

Cover

17. The load-rating of the access cover must be adequate for the expected traffic conditions.
18. The access lids will only fit into the frame one way – ensure the frame is orientated correctly to provide easy access to the inside of the tank when the covers are removed.
19. Place the frame on top of the tank flange and concrete-in to required surface level.
20. Apply grease to the 'mating' surfaces of the lid sections. This helps to prevent corrosion, assists lid removal and helps create a gas tight seal.
21. If the cover is a concrete infill type, pour concrete into the cover and trowel off to the required level.

Paneltim™ Tank Installation

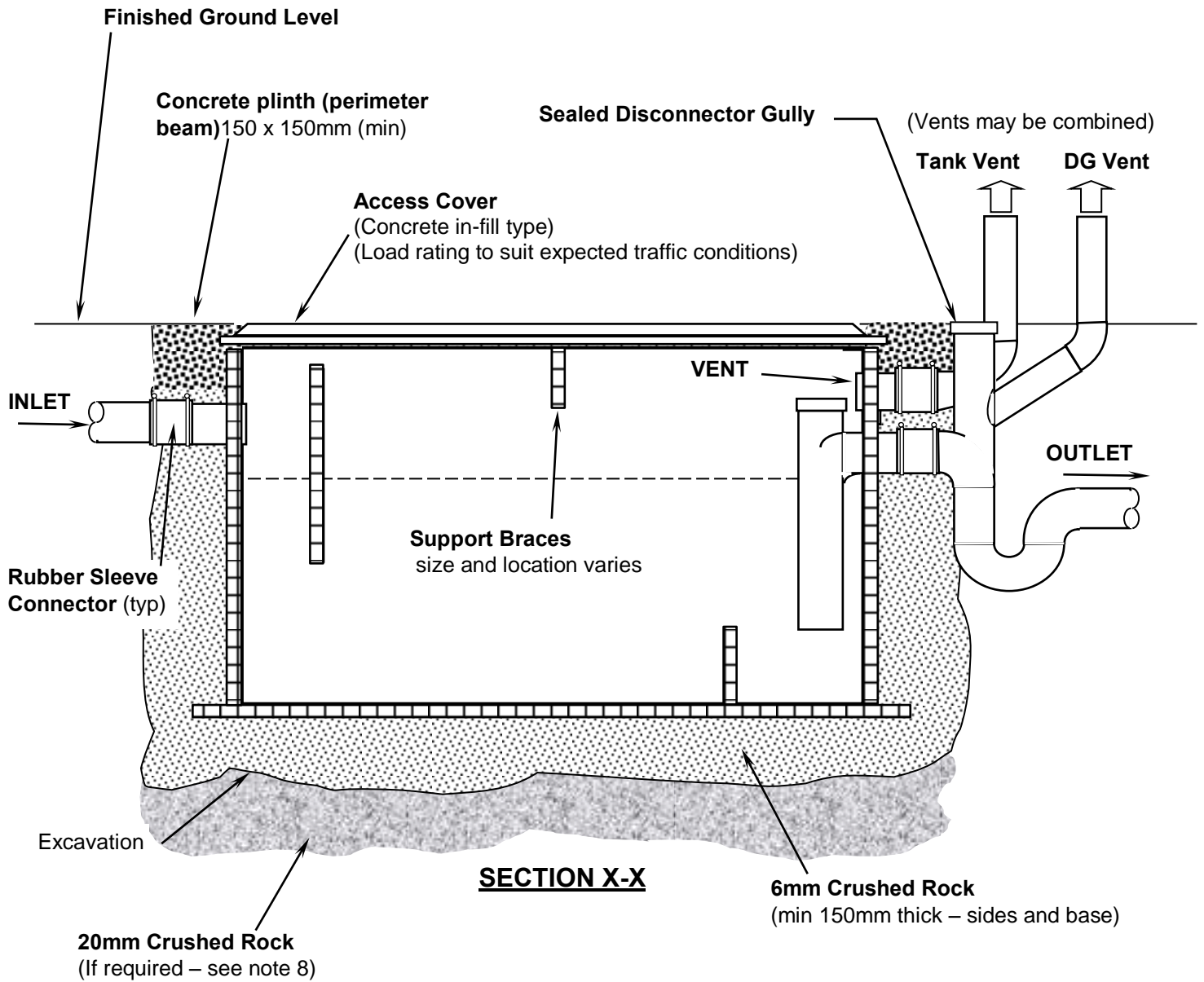

NOTE: Baffle and internal pipe configurations vary according to tank type capacity and/or customer requirements. All attempts should be made to ensure external connections correspond as close as possible to these drawings.

Installation and approval conditions may vary from region to region. This information is provided as a guide only for a typical below-ground tank installation. Viking Plastics reserves the right to alter or change information at any time and without notice.

INSTALLATION & CLEANING GUIDELINES

BELOW GROUND TANKS- THIN SKIN

The information provided herein is informative only and it applies to the below-ground installation of Thin Skin fabricated Trade Waste Pre-Treatment Tanks. As rules and regulations differ from region to region, prior to proceeding we recommend the installing person verify that the procedures mentioned in this document satisfy the requirements of the local Authorities and building off-sets. In most cases a geo-technical report is required.

Trade Waste Authorities state that below-ground tanks must be surrounded with concrete (minimum 100mm thick walls and base).

Siting Considerations

1. The tank should be located as close as practical to source of contaminated water.
2. Ease of accessibility for maintenance.
3. Water tap for the purpose of wash-down should be located nearby and be fitted with a backflow prevention device.
4. The load-rating of the tank cover must be adequate for the expected traffic conditions.
i.e. Pedestrian = light-duty, passenger vehicles = medium-duty or heavy commercial vehicles = heavy-duty.

Excavation & Preparation

5. The ideal excavation size will leave at least a 100mm cavity on all four sides and underneath the tank.
6. In the event that the sub-surface earth is particularly wet or soft, the earth under the tank should be compacted and, if necessary, filled with 20mm crushed rock to 100mm below base of tank. A geo-technical report may be required.
7. Verify that inlet, outlet and vent pipe levels match the level of the pipe spigots on the tank.
8. Concrete to be poured around the tank should be a minimum of 32mpa.

Bracing and Pouring Concrete

9. Pour 100mm concrete pad, (mesh-reinforced if local conditions require it).
10. Insert Y12 reinforcing bars through holes in the tank keying strips.
11. Place tank on top of concrete pad.
12. Install internal bracing (required to prevent collapse of the tank walls under the weight of wet concrete).
We suggest using Timber Flooring or Structural Plywood and timber noggins at maximum 500mm centres for this purpose (see diagrams overleaf).
Alternatively use stud and noggin frames spaced at maximum 500mm centres – vertical and horizontal.
13. We recommend installing end wall bracing for tank widths exceeding 500mm.
14. Ensure walls are well supported, plumb and that bracing will not move or dislodge during concrete pour.
15. Pour concrete in at least two stages.
Stage 1 to a low level to set the tank in position and to ensure it will not float.
16. Pour concrete evenly all around to prevent tank lateral movement.
The tank may be progressively filled with water during the concrete pour to maintain equal pressures and to help prevent the tank from floating.
17. Do not remove the internal tank bracing until the concrete has adequately cured.

Cover

18. The load-rating of the access cover must be adequate for the expected traffic conditions.
19. The access lids will only fit into the frame one way – ensure the frame is orientated correctly to provide easy access to the inside of the tank when the covers are removed.
20. Place the frame on top of the tank flange and concrete-in to required surface level.
21. Apply grease to the 'mating' surfaces of the lid sections. This helps to prevent corrosion, assists lid removal and helps create a gas tight seal.
22. If the cover is a concrete infill type, pour concrete into the cover and trowel off to the required level.

Bracing Recommendations for Below Ground Tanks

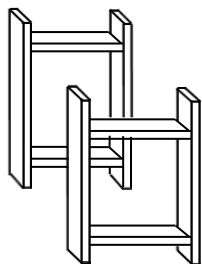

Bracing made from
70 x 35 pine

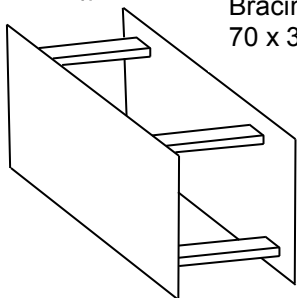

Bracing made from ply and
70 x 35 pine

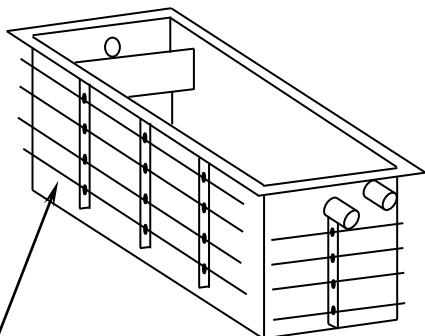

Y12 reinforcing bars through
holes in keying strips



A well braced tank

Bracing to fit between outlet pipe and baffle.

Also brace tank end walls as shown in photo above.

Stud and noggins to be at 500mm centres.

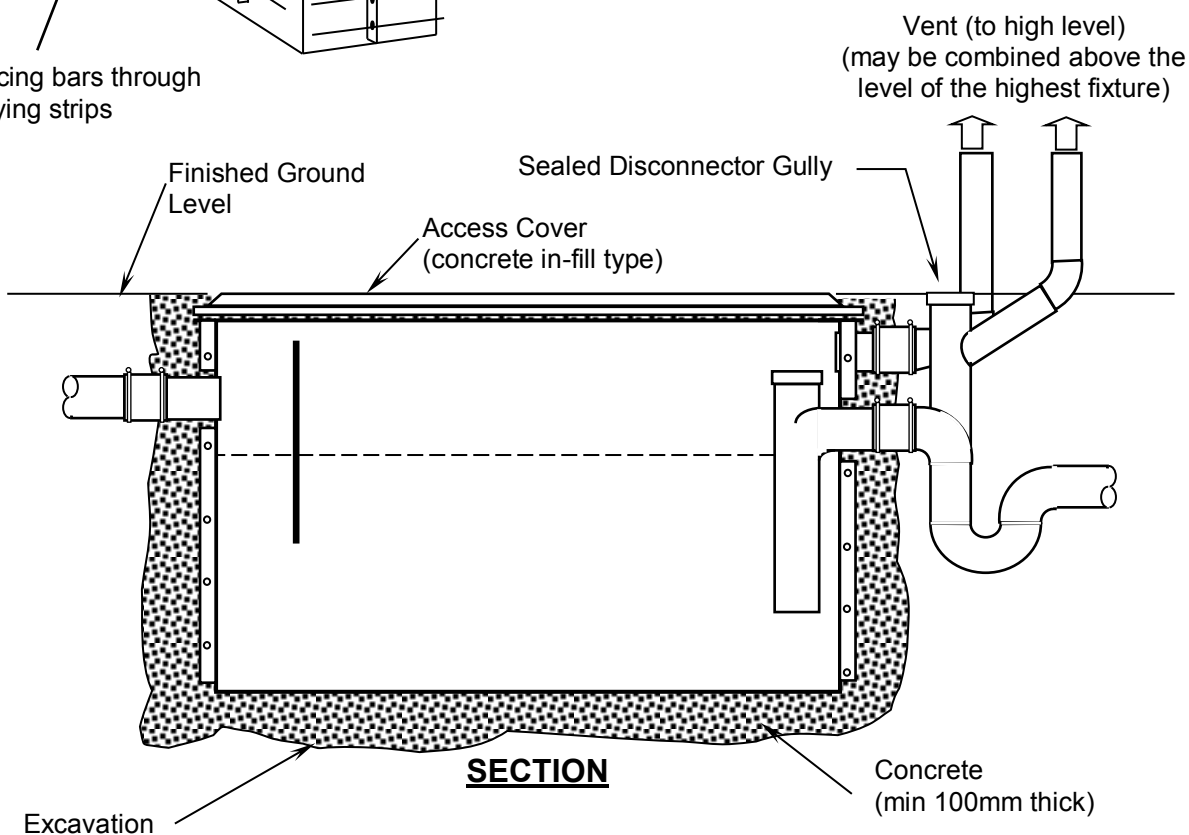

Note: Baffle and internal pipe configurations vary according to tank type, capacity and/or customer requirements.

Installation and approval conditions may vary from region to region. This information is provided as a guide only for a typical below-ground tank installation. Viking Plastics reserves the right to alter or change information at any time and without notice.