

- > below-ground installation.
- > required in commercial food preparation areas.
- > the function of a grease trap is to slow the flow of warm/hot greasy water thus allowing it to cool. As the water cools, the grease and oil separate and float to the top, solids to settle on the bottom of the tank and the cleaner/cooler water flows out to sewer.

Below-ground

Capacity litres	Internal Dimensions mm			
	Length	Width	Water	Height
250	900	600	470	770
300	900	600	560	860
350	900	600	650	950
400	1250	600	540	840
500	1250	600	670	970
600	1250	750	640	940
700	1400	750	670	970
750	1400	750	720	1020
800	1400	750	760	1060
900	1400	750	860	1160
1000	1400	750	960	1260
1100	1400	750	1060	1360
1500	1900	750	1060	1360
2000	2400	750	1120	1420
2500	2400	900	1160	1460
3000	2900	900	1150	1450
4000	2900	900	1530	1830
5000	4000	900	1400	1700
6000	4000	900	1700	2000
7500	4500	1200	1400	1700
10000	4500	1200	1850	2150

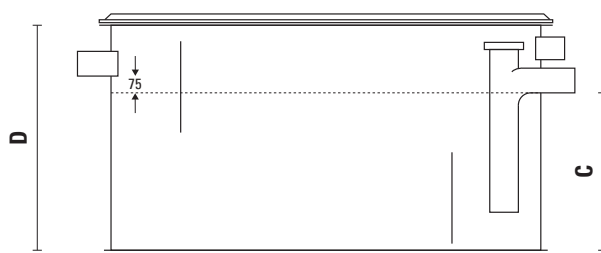

Section View

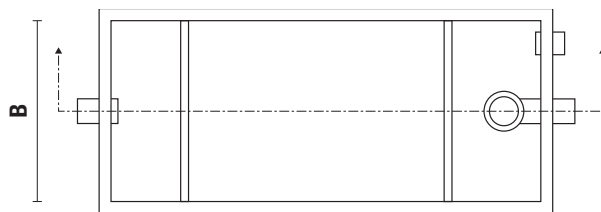

Plan View (without lid)

Grease Trap (Interceptor) model VP9-1

For below-ground installations

- > Manufactured from Polypropylene (PP) and/or Polyethylene (PE) materials, this tank is suitable for below-ground installations.
- > The tank must be surrounded with 100mm thick concrete walls and base.
- > Note: During installation the tank must be adequately supported internally to prevent the walls from collapsing during the concrete pour.
- > Standard tanks are fitted with 100mm nb. Inlet, Outlet and Vent pipes.
- > Tank is fitted with a 50mm flat-rim flange and external keyring strips.
- > Metal access covers (sold separately) capable of being removed by one man should be fitted on top.
- > Metal access covers are available in various types including concrete in-fill, solid top and tiling edge. Weight loading must also be specified as required (pedestrian, car or heavy truck).
- > Tank dimensions and pipework positions conform to Trade Waste recommendations but may be arranged during manufacture to suit the installation requirement.
- > When space limitations dictate, equivalent capacity tanks can be manufactured to order.

Bracing Recommendations for Below Ground Tanks

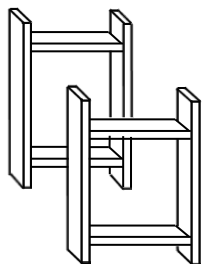

Bracing made from
70 x 35 pine

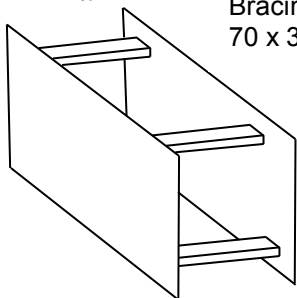

Bracing made from ply and
70 x 35 pine

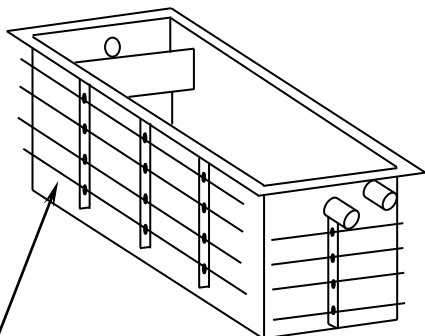

Y12 reinforcing bars through
holes in keying strips



A well braced tank

Bracing to fit between outlet pipe and baffle.

Also brace tank end walls as shown in photo above.

Stud and noggins to be at 500mm centres.

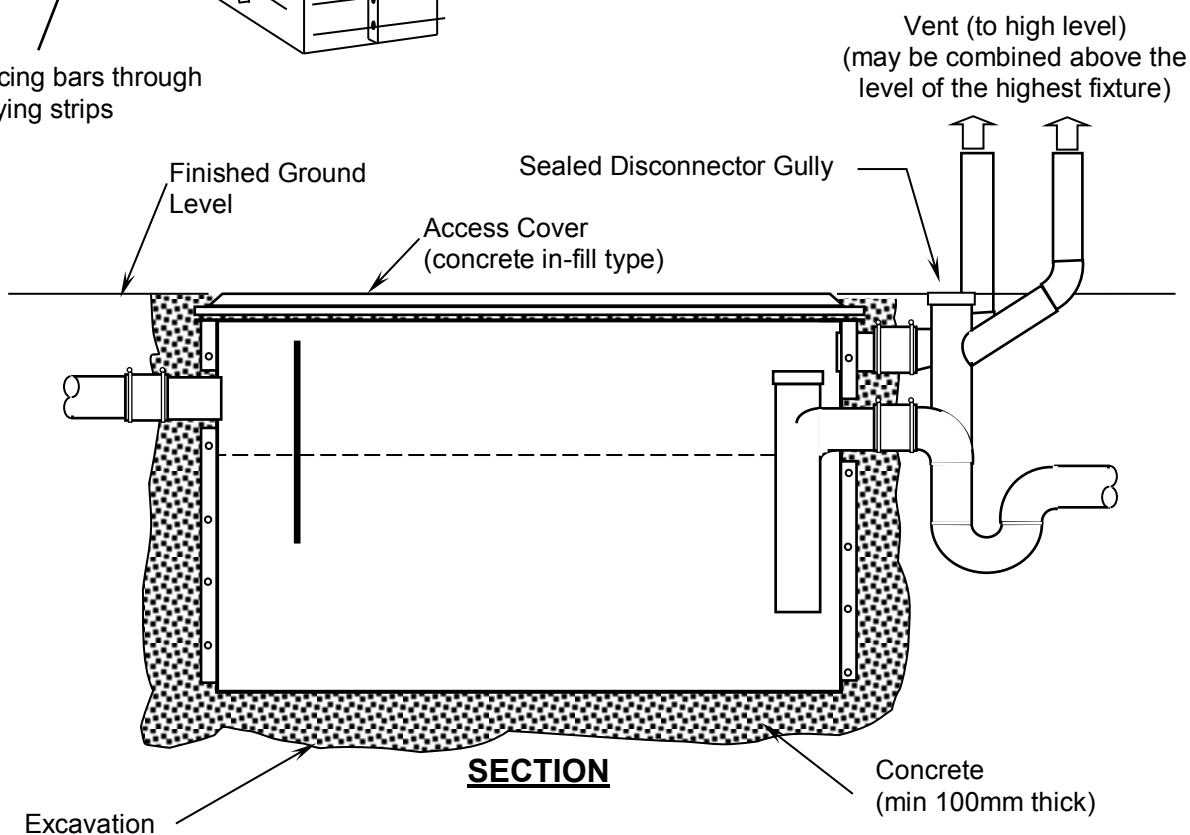

Note: Baffle and internal pipe configurations vary according to tank type, capacity and/or customer requirements.

Installation and approval conditions may vary from region to region. This information is provided as a guide only for a typical below-ground tank installation. Viking Plastics reserves the right to alter or change information at any time and without notice.

INSTALLATION & CLEANING GUIDELINES

BELOW GROUND TANKS- THIN SKIN

The information provided herein is informative only and it applies to the below-ground installation of Thin Skin fabricated Trade Waste Pre-Treatment Tanks. As rules and regulations differ from region to region, prior to proceeding we recommend the installing person verify that the procedures mentioned in this document satisfy the requirements of the local Authorities and building off-sets. In most cases a geo-technical report is required.

Trade Waste Authorities state that below-ground tanks must be surrounded with concrete (minimum 100mm thick walls and base).

Siting Considerations

1. The tank should be located as close as practical to source of contaminated water.
2. Ease of accessibility for maintenance.
3. Water tap for the purpose of wash-down should be located nearby and be fitted with a backflow prevention device.
4. The load-rating of the tank cover must be adequate for the expected traffic conditions.
i.e. Pedestrian = light-duty, passenger vehicles = medium-duty or heavy commercial vehicles = heavy-duty.

Excavation & Preparation

5. The ideal excavation size will leave at least a 100mm cavity on all four sides and underneath the tank.
6. In the event that the sub-surface earth is particularly wet or soft, the earth under the tank should be compacted and, if necessary, filled with 20mm crushed rock to 100mm below base of tank. A geo-technical report may be required.
7. Verify that inlet, outlet and vent pipe levels match the level of the pipe spigots on the tank.
8. Concrete to be poured around the tank should be a minimum of 32mpa.

Bracing and Pouring Concrete

9. Pour 100mm concrete pad, (mesh-reinforced if local conditions require it).
10. Insert Y12 reinforcing bars through holes in the tank keying strips.
11. Place tank on top of concrete pad.
12. Install internal bracing (required to prevent collapse of the tank walls under the weight of wet concrete).
We suggest using Timber Flooring or Structural Plywood and timber noggins at maximum 500mm centres for this purpose (see diagrams overleaf).
Alternatively use stud and noggin frames spaced at maximum 500mm centres – vertical and horizontal.
13. We recommend installing end wall bracing for tank widths exceeding 500mm.
14. Ensure walls are well supported, plumb and that bracing will not move or dislodge during concrete pour.
15. Pour concrete in at least two stages.
Stage 1 to a low level to set the tank in position and to ensure it will not float.
16. Pour concrete evenly all around to prevent tank lateral movement.
The tank may be progressively filled with water during the concrete pour to maintain equal pressures and to help prevent the tank from floating.
17. Do not remove the internal tank bracing until the concrete has adequately cured.

Cover

18. The load-rating of the access cover must be adequate for the expected traffic conditions.
19. The access lids will only fit into the frame one way – ensure the frame is orientated correctly to provide easy access to the inside of the tank when the covers are removed.
20. Place the frame on top of the tank flange and concrete-in to required surface level.
21. Apply grease to the 'mating' surfaces of the lid sections. This helps to prevent corrosion, assists lid removal and helps create a gas tight seal.
22. If the cover is a concrete infill type, pour concrete into the cover and trowel off to the required level.